

DCM Company

Identification Guide

1-800-VAN-GLAS

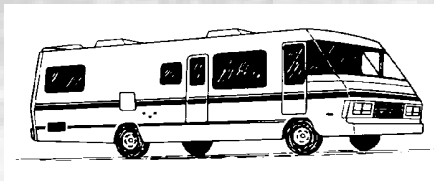

Motor Home

Domestically Manufactured Windshields;
Replacement Glass & Windows

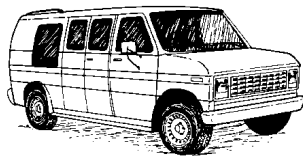

Van Conversion

Original Windows & Glass;
SOLUTIONS® Replacements for
Obsolete Windows



Shuttle Bus

Replacement Glass & Windows

DCM Company - A Division of RV Marketing, Inc.

2016 Borneman Avenue, Elkhart, Indiana 46517

CustomerService@dcmco.com

www.dcmco.com



*"Experience
Our Experience"*

Toll-free: 1-800-VAN-GLAS (1-800-826-4527)

Toll-free fax: 1-888-485-3377

Phone: 574-294-6989

Fax: 574-294-7599

***Your
One-
Stop
Source***

Van, RV, and Bus Replacement Glass



"Experience
Our Experience"

DCM Company
A Division of RV Marketing, Inc.
2016 Borneman Ave.
Elkhart, IN 46517

Toll-free: 1-800-548-0432
Toll-free fax: 1-888-485-3377
Tel: 574-294-6989
Fax: 574-294-7599
www.dcmco.com
CustomerService@dcmco.com

Guarantee Business is Run Your Way. . . with a company designed to serve you, the auto glass installer.

As a trade-based company, DCM Company's policy is to provide list price only to those outside of the industry. We believe every store has the right to set their own margins.

Rely on our dedication to the glass industry to provide you with:

- Van conversion replacement glass and replacement windows.
- Motor home windshields, replacement glass, and replacement windows.
- Shuttle bus replacement glass and replacement windows.
- Bus windshields and replacement windows.

Use the key identification points in the following pages to help us identify the replacement glass, window, or windshield you need. Quick reference rolodex cards are available, too. This identification guide is available on-line at www.dcmco.com.

Over 75 years combined staff experience allows us to quickly identify windows for exact replacements. Many windows are available to ship the same day from our inventory of over 4,000 windows. All windows are packed in special 2-way shipping boxes for convenience.

Use our toll-free 800 number, good throughout the U.S. and Canada, to begin your search for replacement glass. We welcome the opportunity to become Your One-Stop Source.



Van Conversion Replacement Glass and Replacement Windows



DCM Company
A Division of RV Marketing, Inc.
2016 Borneman Ave.
Elkhart, IN 46517

Toll-free: 1-800-VAN-GLAS
Toll-free fax: 1-888-485-3377
www.dcmco.com
CustomerService@dcmco.com

Understanding Van Conversion Windows

Van conversion windows have undergone manufacturing changes over the years. These changes affect how replacement work is handled.

Originally, the glass in a van conversion window was 3/16" thick and bent before installation in a frame. Around 1981, window manufacturers began using 1/8" thick flat glass that is secured in a flat window frame. The flat window is then contoured in the last stages of manufacturing to match the contoured side of the van's body.

When replacing glass only in a van conversion window, the glass demonstrates its memory and returns to a flat state. Flat glass must be pressed into the contoured frame and secured with a glass clip during replacement work.

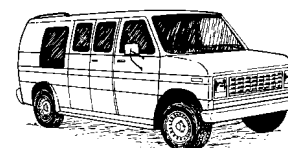

Windows with a clip are called reglazable and allow for glass replacement. Windows without a clip, called u-channel, do not allow for glass replacement. When u-channel windows are damaged, the entire window must be replaced.

Window Manufacturers

Replacements for obsolete windows from current manufacturers and out-of-production manufacturers are available from our 4,000+ window inventory. In-stock windows include items manufactured by:

| | | | | |
|---|-------------------|-----------------|------------------|-----------------|
| <i>Able</i> | <i>Ameriglass</i> | <i>ASP</i> | <i>B.W.I.</i> | <i>Creation</i> |
| <i>Excel</i> | <i>GGT</i> | <i>Glasscon</i> | <i>Hehr</i> | <i>Mark III</i> |
| <i>Phase V</i> | <i>RJ Sampers</i> | <i>Spicer</i> | <i>Statewide</i> | |
| <i>Transportation Products (T.P.I.)</i> | | <i>Vantage</i> | <i>Westover</i> | <i>Zimmer</i> |

Van Conversion Window Style Examples

Many shapes and styles of van conversion windows have been used over the years. Below are the most common styles.



Angled t-slider



T-slider



Vertical lift



Solid



Half-slider



2-Piece bonded

Key Identification Points

- Height & width, outside of frame to outside of frame
- Temper stamp on glass
- Name of van converter
- Tint of the glass



Shrouds

Vacuum formed ABS shrouds and injection molded shrouds are available, too.

Take careful notes on any unusual window style. Use the following inquiry page to record the information needed for the replacement.

Van Conversion Bolt-On Slider Glass Handle



DCM Company
A Division of RV Marketing, Inc.
2016 Borneman Ave.
Elkhart, IN 46517

Toll-free: 1-800-VAN-GLAS
Toll-free fax: 1-888-485-3377
www.dcmco.com
CustomerService@dcmco.com

Illustration of Bolt-On Slider Glass Handle

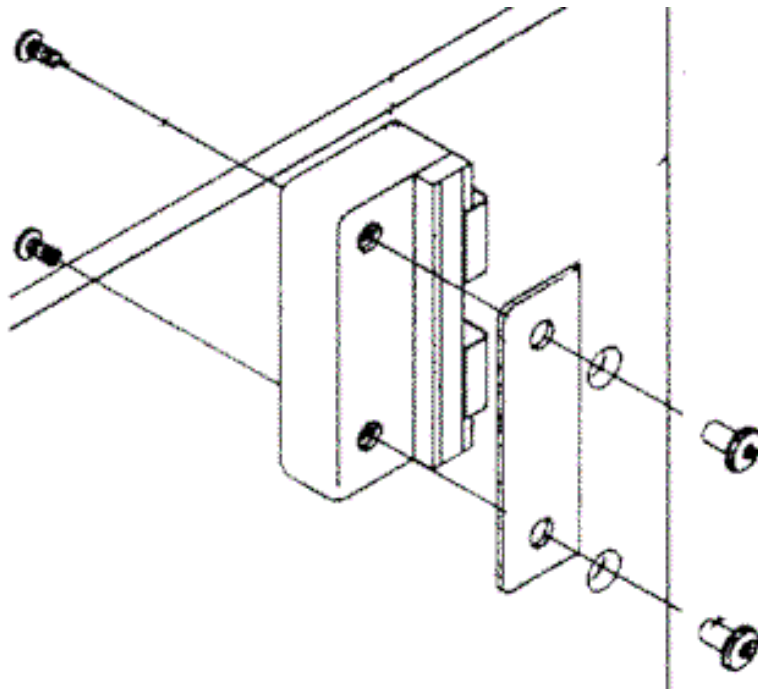

Van Conversion Replacement Glass and Replacement Windows

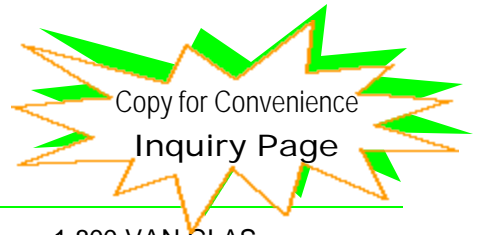

"Experience Our Experience"

DCM Company
A Division of RV Marketing, Inc.
2016 Borneman Ave.
Elkhart, IN 46517

Toll-free: 1-800-VAN-GLAS
Toll-free fax: 1-888-485-3377
www.dcmco.com
CustomerService@dcmco.com

Complete the following information and fax this page or call us to begin your search for van conversion replacement glass and replacement windows.

Your Name: _____ Your Phone: _____
Your Company: _____ Your Fax: _____

Vehicle Information

Year, Make & Model of Vehicle: _____ Van Converter: _____

Outside Frame Dimensions*

Width at Top(↻): _____ Width at Bottom(↻): _____
Height at Front(↻): _____ Height at Rear(↻): _____ Diagonals(↗ ↘): _____

*If window has an **ANGLE**, measure the width at the **WIDEST POINT**.

Location of Window (Choose one)

Driver Front Driver Rear Passenger
Side Cargo Doors Rear Cargo Doors Other: _____

Glass Information

DOT#: _____ Black Band on Glass?: _____
Tint of the Glass: 31% 55% GL 20 Other: _____
Number of Pieces of Glass in Window: _____ How Does Window Open?: _____

Color of Frame (Choose one)

Black Black with Chrome Strip
Brown White Other: _____

Slider Glass

Slider Glass Handle: Bolted or Pressed On (Glued On): _____
Slider Glass Screen: Sliding or Stationary: _____

Type of Window (Choose one)

Reglazable U-Channel
Manufacturer's Name on the Window or Handle or Drain Slot Covers?: _____

Other

Motor Home Windshields, Replacement Glass and Replacement Windows



"Experience Our Experience"

DCM Company
A Division of RV Marketing, Inc.
2016 Borneman Ave.
Elkhart, IN 46517

Toll-free: 1-888-VAN-GLAS
Toll-free fax: 1-888-485-3377
www.dcmco.com
CustomerService@dcmco.com

Motor Home Windshields

Windshields for over 600 motor home (Class A) models are ready to ship the same day from our inventory. Below is a list of current and out-of-production motor homes. We can provide windshields for these models and others not listed.



| | | | | | | |
|------------------|-----------------|-------------------|-------------------------|------------------------|--------------|-----------|
| Aero Cruiser | Aero Sport | Aerobus | Affinity | Airex | Airstream | Allegro |
| Alumalite | Ambassador | American Eagle | American Coach | American Cobra | Americana | |
| Americoach | Americoach II | Angola | Apollo | Argosy | Aristocrat | Avco |
| Barth | Beachcraft | Beaver | Beaver Craft | Blue Bird Wander Lodge | | Bornfree |
| Bounder | Brave | Cabana | Cabaret | Caribou | Catalina | Cavalier |
| Challenger | Champion | Chieftain | Chinook | Citation | Coachmen | Cobra |
| Columbus | Concept | Condor II | Contessa | Coronado | Corsair | |
| Continental | Country Coach | Cross Country | Crown Royal Sig. Series | | Cruise Air | |
| Cruise Master | Custom Coach | Damon | Diplomat | Forest River | Discover | Discovery |
| Dodge Motor Home | Dolphin | Dutchman | Dynasty | Eagle by Marathon | Elandon | Elante |
| Ecapatan | Eldorado | Elite | Empress | Encore | Encounter | Escaper |
| Establishment | Euro Coach | Euro Premier | Executive | Explorer | Flagship | Flair |
| Fleetwood | Flexible | Firan Motor Coach | Four Winds | Foretravel | Freedom | Galbreath |
| Georgie Boy | GMC Motor Home | Grand Villa | Grandville | Guardian Pacific | Gulf Stream | Hawkins |
| Heritage | Holiday Rambler | Honey | Horizon | Indian | Innsbruck | Islander |
| Itasca | Jamboree | Jubilee | Kayot | Komfort | Kountry Air | |
| Kountry Star | Krager | Land Yacht | Landau | Lark | Lasharo | Legacy |
| Leisure Craft | Leocraft | Lexington | Limited | London Aire | Magna | Malibu |
| Mallard | Marathon | MCI | Midas | Mitchell Motor Coach | | |
| Mobile Traveler | Monaco | Monitor | Monteray Coach | MTL | Navigator | Neoplan |
| Newell | Newmar | Newport | Overland | Pace Arrow | Palm Beach | |
| Path Finder | Patriot | Phaser | Pinnacle | Prevost | Pursuit | Ramblet |
| Regency | Revcon | Road Master | Rockwood | Royale Coach | Safari | |
| Sea Breeze | Shasta | Signature | Silver Eagle | Southwind | Sports Coach | Sprint |
| Sprinter | Starcraft | Starfire | Streamline | Sun Crest | Sun Flyer | |
| Sun Raider | Sun Sport | Superior | Swinger | Taravoy | Telstar | Tidwell |
| Tioga | Titan | Tourmaster | Travco | Travel Car Lodge | Travel Craft | |
| Travel Equipment | Travel Master | Travel Queen | Travel World | Trek | Trend Setter | Triple E |
| Tropical | Ultra Star | Van American | Venture | Viscount | Vixen | Vogue |
| Voyager | Wanderer | Windjammer | Winnebago | Winnie Minnie | Xplorer | XMC |
| Yellowstone | | | | | | |

Windshield Key Identification Points

- Year, Make & Model
- Model # & Serial #
- Block Size
- Tint - Shaded - Black Band
- Bug Information

Replacement Glass and Replacement Windows

Replacement glass and replacement windows are available for both Class A and Class C motor homes. Use the following inquiry page to record the information needed for the replacement.

Shuttle Bus Replacement Glass and Replacement Windows



DCM Company
A Division of RV Marketing, Inc.
2016 Borneman Ave.
Elkhart, IN 46517

Toll-free: 1-800-548-0432
Toll-free fax: 1-888-485-3377
www.dcmco.com
CustomerService@dcmco.com

Replacement Glass and Replacement Windows

The same manufacturing techniques produce shuttle bus windows as well as van conversion windows. While van conversion windows are always contoured, shuttle bus windows can be either flat or contoured. Also, windows used in shuttle buses must be safety tested and certified. Each window manufacturer has certification documents on file for each size of their shuttle bus windows.

Another special feature of the shuttle bus window is the placement of an egress or emergency exit window on the bus. Egress windows will usually be labeled as well as have red emergency handles on the inside. Before searching for a replacement on a shuttle bus window, take notice if the window is flat or contoured and whether or not the window is for emergency exit.

The following is a partial list of bus manufacturers whose replacement windows and replacement glass we can provide. Please call for replacements on other models.

| | | |
|---------------------|-----------------------|-----------------|
| <i>Blue Bird</i> | <i>Carpenter</i> | <i>Champion</i> |
| <i>Collins</i> | <i>Diamond</i> | <i>Eldorado</i> |
| <i>Goshen Coach</i> | <i>LAG</i> | <i>MCI</i> |
| <i>Metrotrans</i> | <i>National Coach</i> | <i>Neoplan</i> |
| <i>Prevost</i> | <i>Startrans</i> | <i>Supreme</i> |
| <i>Thomas</i> | <i>Turtle Top</i> | <i>Van Hool</i> |

Shuttle Bus Window Style Examples

Many shapes and styles of shuttle bus windows have been used over the years. Below are the most common styles.



Bottom t-slider



Top t-slider



Vertical lift



Double Top-T

Key Identification Points

- Height & width, outside of frame to outside of frame
- Temper stamp on glass
- Name of bus company
- Flat or contoured body
- Tint of the glass
- Regular or emergency window

Take careful notes on any unusual windows styles. Use the following inquiry page to record the information needed for the replacement.

Shuttle Bus Replacement Glass and Replacement Windows

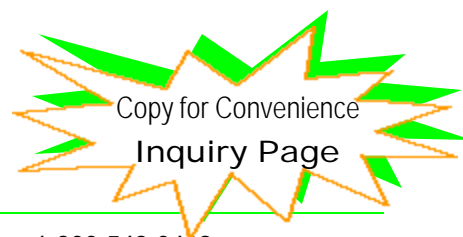

"Experience Our Experience"

DCM Company
A Division of RV Marketing, Inc.
2016 Borneman Ave.
Elkhart, IN 46517

Toll-free: 1-800-548-0432
Toll-free fax: 1-888-485-3377
www.dcmco.com
CustomerService@dcmco.com

Complete the following information and fax this page or call us to begin your search for shuttle bus replacement glass and replacement windows.

Your Name: _____ Your Phone: _____

Your Company: _____ Your Fax: _____

Vehicle Information

Year, Make & Model of Vehicle: _____ Bus Company: _____

Serial Number: _____ Body Number: _____

Side of Bus Body: Flat or Contoured

Outside Frame Dimensions*

Width at Top(☞): _____ Width at Bottom(☞): _____

Height at Front(♯): _____ Height at Rear(♯): _____ Diagonals(↖↗): _____

*If window has an **ANGLE**, measure the width at the **WIDEST POINT**.

Location of Window: _____

Glass Information

DOT#: _____ Black Band on Glass?: _____

Tint of the Glass: 31% 55% GL 20 Other: _____

Number of Pieces of Glass in Window: _____ How Does Window Open?: _____

Color of Frame: _____ Part Number: _____

Slider Glass

Slider Glass Handle: Bolted or Pressed On (Glued On): _____

Slider Glass Screen: Sliding or Stationary: _____

Type of Window (Choose one)

Reglazable U-Channel

Escape Window (Egress) Regular
(Escape window will have red handles.)

Manufacturer's Name on the Window?: _____

DCM Company Returned Goods Policies & Procedures



"Experience
Our Experience"

DCM Company
A Division of RV Marketing, Inc.
2016 Borneman Ave.
Elkhart, IN 46517
www.dcmco.com

Toll-free: 1-800-548-0432
Tel: 574-294-6989
Toll-free fax: 1-888-485-3377
Fax: 574-294-7599
CustomerService@dcmco.com

Effective January 1, 1993

It is always the intent of DCM that an order we ship gets to you in good order, fits, and is installed by you, all without difficulty. However, we are human and occasionally make a mistake, you are human and occasionally order the wrong item, and freight carriers are human and occasionally damage something. In these instances, the following policies apply:

Returned Goods Authorization – In all cases, an RGA number is required and is available from a DCM Customer Service Representative.

Inspection – It is your responsibility to check each shipment at time of arrival for accuracy and damage. Any discrepancy should be reported to a DCM Customer Service Representative right away.

1. If we have shipped you the wrong item, we will, at our expense, ship you the proper item and arrange to have the wrong one picked up. We do ask that you repackage the item in a manner that will allow it to be received back in a saleable condition.

2. If you have ordered the wrong item we will determine if the item is a standard item or special order.

Standard items can be returned for convenience of the customer but are subject to a 20% restocking charge on the item cost with no allowance for freight and must have been purchased within the last 30 days.

Special order items may not be returned. We recommend that you receive a significant deposit when ordering these.

3. **Damaged Goods** – Since damage claim procedures vary from one carrier to another, it is imperative that you contact a DCM Customer Service Representative right away so we can take the proper steps to replace the damaged item and have the damaged one picked up.

Billing – All replacement shipments will be invoiced as an original shipment. Credit for returned merchandise, for any reason, is subject to our standing credit and refund policy.

Credit and Refund Policy – All credit for returned merchandise is subject to our inspection upon its arrival at the DCM warehouse. All merchandise must be received in a saleable condition for credit to be issued.

Upon inspection approval a credit memo will be issued to be applied to a future purchase.

For C.O.D. customers our refund policy is as follows:

1. For DCM error or damage shipment, 30 days after the issue date of an unused credit memo a refund check will be issued and the credit memo cancelled.
2. For customer convenience returns, 60 days after the issue date of an unused credit memo a refund check will be issued and the credit memo cancelled.

Minimum Invoice – Due to invoicing costs, we require a \$15 minimum invoice.

Returned Checks – Any returned check is subject to a \$25 charge for each time it is returned and that customer's terms with DCM are subject to immediate review.

Account Information & Agreement



DCM Company
 A Division of RV Marketing, Inc.
 2016 Borneman Ave.
 Elkhart, IN 46517
 www.dcmco.com

Toll-free: 1-800-548-0432
 Tel: 574-294-6989
 Toll-free fax: 1-888-485-3377
 Fax: 574-294-7599
 CustomerService@dcmco.com

Legal Name _____ Date _____
 Trade Name(s) _____ Phone _____
 Mailing Address _____ Fax _____
 City/State/Zip _____ ___Corporation ___Proprietorship ___Partnership
 Shipping Address _____ Parent Company _____
 City/State/Zip _____ City/State/Zip _____

Complete the following information for all corporate officers, partners, or individual proprietors.

Name and Title _____ Name and Title _____
 Home Address _____ Home Address _____
 City/State/Zip _____ City/State/Zip _____
 Home Phone _____ Home Phone _____
 Social Security Number _____ Social Security Number _____

Name and Title _____ Name and Title _____
 Home Address _____ Home Address _____
 City/State/Zip _____ City/State/Zip _____
 Home Phone _____ Home Phone _____
 Social Security Number _____ Social Security Number _____

In Business Since _____ Date of Incorporation _____
 Amount of Credit Desired _____ Monthly Requirements _____
 Line of Business _____ Products Which Will Be Purchased _____
 State Tax Exemption Number* _____
 (*Please attach form)

Bank References

Name of Bank _____ Officer _____
 Mailing Address _____ Account Number(s) _____
 City/State/Zip _____
 Phone _____

****Please complete Trade References on reverse side.****

Trade References



DCM Company
 A Division of RV Marketing, Inc.
 2016 Borneman Ave.
 Elkhart, IN 46517
 www.dcmco.com

Toll-free: 1-800-548-0432
 Tel: 574-294-6989
 Toll-free fax: 1-888-485-3377
 Fax: 574-294-7599
 CustomerService@dcmco.com

Complete Addresses Must Be Furnished (MUST INCLUDE FAX NUMBERS)

| | |
|-----------------------|-----------------------|
| Name _____ | Name _____ |
| Mailing Address _____ | Mailing Address _____ |
| City/State/Zip _____ | City/State/Zip _____ |
| Phone _____ | Phone _____ |
| Fax _____ | Fax _____ |

| | |
|-----------------------|-----------------------|
| Name _____ | Name _____ |
| Mailing Address _____ | Mailing Address _____ |
| City/State/Zip _____ | City/State/Zip _____ |
| Phone _____ | Phone _____ |
| Fax _____ | Fax _____ |

The undersigned represents that the information supplied above is true and correct. Should credit be extended to the undersigned, the undersigned agrees to the following terms:

1. All invoices will be promptly paid when due.
2. Any invoice not paid when due will be subject to a finance charge of up to 1 1/2% per month, not to exceed the maximum rate permitted by law.
3. In the event of any default, the undersigned shall be responsible for all costs of collection, damages, and expenses including actual attorney's fees and costs, whether or not litigation is commenced.
4. Buyer(s) agree that venue of any action to enforce any provisions of this agreement, shall be in Elkhart County, State of Indiana.
5. The undersigned hereby authorizes any bank or other grantor of credit to provide information regarding the character, reputation, financial responsibility, and indebtedness of the undersigned.

Date _____

Signature _____
 (Corporate Officer or Owner)

Title _____

Our terms are subject to prevailing terms of sale and credit approval.